

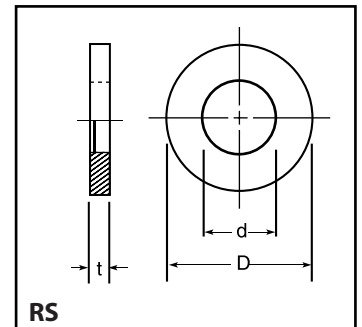

# HARDENED PLAIN WASHERS

**ROCKSIDE  
EXPORT LIMITED**

Standard Specification : ASTM F 436  
 Material : Medium Carbon Steel  
 Type : Type 1  
 Hardness : HRC 38 to 45  
 Surface Finished : Black, Electro Galvanized,  
 Hot Dipped Galvanized



## DIMENSIONS OF HARDEN FLAT WASHERS

NOM SIZE OF BOLT	INSIDE DIAMETER		OUTSIDE DIAMETER		THICKNESS		HARDNESS BLACK	HARDNESS HDG
	MIN	MAX	MIN	MAX	MIN	MAX		
M12	14	14.4	25.7	27	3.4	4.6	38-45	26-45
M14	16	16.4	28.7	30	3.4	4.6	38-45	26-45
M16	18	18.4	32.4	34	3.4	4.6	38-45	26-45
M18	20	20.5	36.4	38	3.4	4.6	38-45	26-45
M20	22	22.5	40.4	42	3.4	4.6	38-45	26-45
M22	24	24.5	42.4	44	3.4	4.6	38-45	26-45
M24	26	26.5	48.4	50	3.4	4.6	38-45	26-45
M27	30	30.5	54.1	56	3.4	4.6	38-45	26-45
M30	33	33.6	58.1	60	3.4	4.6	38-45	26-45
M33	36	36.6	64.1	66	3.4	4.6	38-45	26-45
M36	39	39.6	70.1	72	3.4	4.6	38-45	26-45

AS PER ASTM F436

## HIGH STRENGTH PLAIN WASHERS FOR FRICTION GRIP JOINTS

Material : Medium Carbon Steel  
 Strength Grade : F 35  
 Hardness : HRC 38 to 45  
 Surface Finished : Black, Electro Galvanized,  
 Hot Dipped Galvanized

### DIMENSIONS OF HSFG FLAT WASHERS BS 4395

### DIMENSIONS OF HSFG WASHERS DIN-6914

NOM SIZE OF BOLT	INSIDE DIAMETER		OUTSIDE DIAMETER		THICKNESS		HARDNESS	INSIDE DIA	OUTSIDE DIA	THICKNESS
	MIN	MAX	MIN	MAX	MIN	MAX				
M12	13.4	13.8	28	29	3.1	4.6	38-45	13	17	3
M16	17.4	17.8	36	37	3.1	4.6	38-45	17	30	4
M20	21.1	21.5	43	44	3.1	4.6	38-45	21	37	4
M22	23	23.4	48.5	50	3.4	4.6	38-45	23	39	4
M24	26	26.4	54.5	56	3.4	4.6	38-45	25	44	4
M27	29	29.4	58.5	60	3.4	4.6	38-45	28	50	5
M30	32.4	32.8	64.5	66	3.4	4.6	38-45	31	56	5
M33	35.4	35.8	73.5	75	3.4	4.6	38-45	34	60	5
M36	37.4	37.8	79.5	81	3.4	4.6	38-45	37	66	5

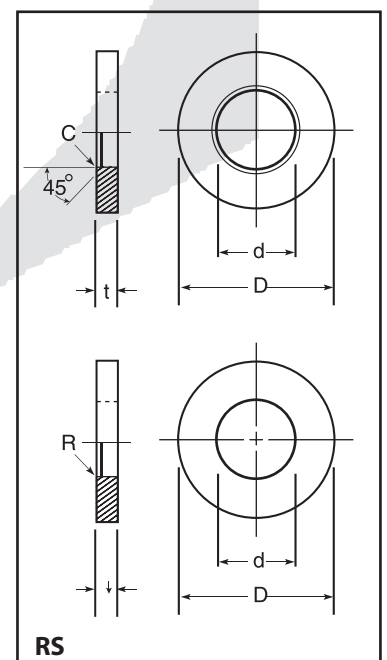

While every care has been taken in the preparation of the information in this catalogue, the company accepts no liability for any loss or damage either direct or consequential arising out of use this catalogue. This compilation is for reference only, for detail refer relevant Original Standards Manuals.

